

MC 250/5 Type 321
MC 400/5 Type 323
MC 440/5 Type 324

MAICO

Picture No.	Part No.	Description	Quantity		
			250	400	440
1	3349	Crankcase right hand	1	1	-
2	3350	Guide bush for pawl pin	1	1	1
3	331	Guide bush	1	1	1
4	1895	Pin 8 h 8x14	2	2	2
5	1787	Stud M 8x28 Din 940	4	4	4
6	3352	Crankcase left hand	1	1	-
7	1831	Tension pin 8x10 Din 7346	2	2	2
8	1888	Pin 5 h x 14 Din 7	1	1	1
9	3353	Inside ring	1	1	1
10	398	Crankcase cover right hand	1	1	1
11	3355	Crankcase cover left hand	1	1	1
12	400	Oil drain plug complete	1	1	1
13	3498	Crankcase gasket	1	1	1
14	3356	Crankcase cover gasket left	1	1	1
15	2969	Crankcase cover gasket right	1	1	1
16	3499	Ventilation pipe	1	1	1
17	1667	Hexagon nut M 6 Din 934	1	1	1
18	407	Sealing ring	7	7	7
19	408	Screw plug M 20x1.5 Din 910	1	1	1
20	410	Sealing ring A 14x18 Din 7603	1	1	1
21	409	Sealing ring A 20x24 Din 7603	1	1	1
22	1533	Cylinder head screw A M 6x18 Din 84	1	1	1
23	1546	Cylinder head screw A M 6x85 Din 84	2	2	2
24	1539	Cylinder head screw A M 6x40 Din 84	7	7	7
25	1538	Cylinder head screw A M 6x35 Din 84	4	4	4
26	1537	Cylinder head screw A M 6x28 Din 84	3	3	3
27	1552	Cylinder head screw A M 8x16 Din 84	1	1	1
28	430	Sealing ring A 8x14 Din 7603	1	1	1
29	2981	Crankshaft complete	1	-	-
30	424	Needle bearing KBK 18x22x24	1	1	1
31	426	Ball bearing 6305 Din 625	1	1	1
32	693	Ball bearing 3305 C 3 Din 625	1	1	1
33	547	Oil seal 32x52x7/9	1	1	1
34	3469	Oil seal 25x52x8	1	1	1
35	713	Spacer ring	1	1	1
36	3470	Duplex sprocket	1	-	-
37	504	Lock washer	1	1	1
38	505	Sleeve pinion nut	1	1	1
39	522	Piston 66.95	1	-	-
40	523	L-ring	1	-	-
41	535	Piston pin	1	-	-
42	536	Piston pin clip	2	2	2
43	2500	Cylinder cpl with exhaust manifold	1	-	-
44	2502	Cylinder head	1	-	-
45	65	Cylinder head gasket	1	-	-
46	721	Cylinder base gasket	1	-	-
47	2967	Cylinder head stud	5	-	-
48	1705	Spring washer B 8 Din 127	9	9	9
49	1670	Hexagon nut M 8 Din 934	4	4	4
50	78	Hexagon nut M 8 Din 6330	5	5	5
51	3386	Clutch guide	1	1	1
52	725	Clutch push pin	1	1	1
53	1869	Ball	14	14	14
54	455	Push pin nut	1	1	1

55	443	Duplex primary chain 3/8x7/32	1	-	-
56	444	Thrust washer	1	1	1
57	3389	Bush	1	1	1
58	2580	Clutch body	1	1	1
59	447	Lock washer	1	1	1
60	448	Clutch nut	1	1	1
61	449	Cup spring	20	20	20
62	3396	Outer clutch disc	6	6	6
63	3390	Inner clutch disc	6	6	6
64	3391	Terminal disc	1	1	1
65	461	Lock ring	2	2	2
66	462	Clutch spindle	1	1	1
67	464	Sealing ring	1	1	1
68	437	Clutch lever	1	1	1
69	1750	Washer B 6.4 Din 9021	1	1	1
70	1667	Hexagon nut M 6 Din 9021	1	1	1
71	3398	Clutch housing (duplex T=41)	1	-	-
72	730	Kickstarter pinion	1	1	1
73	731	Ratchet spring	1	1	1
74	732	Spring cup	1	1	1
75	733	Snap-spring	1	1	1
76	729	Kickstarter ratchet wheel	1	1	1
77	1906	Oval head rivet 4x10 Din 662	8	8	8
78	3433	Mainshaft "MG"	1	1	1
79	3434	3rd gear on mainshaft "M" T=24	1	-	-
80	3435	4th gear on mainshaft "MG" T=26	1	1	1
81	3706	Spacer ring	1	1	1
82	492	Retainer ring	3	3	3
83	3436	Sleeve pinion "M" T=28	1	-	-
84	3454	Sleeve pinion plug	1	1	1
85	3437	Layshaft "M" T=17	1	-	-
86	3456	Washer 2nd gear	1	1	1
87	914	Washer	1	1	1
88	3438	1st gear on layshaft "M1" T=26	1	-	-
89	905	Needle bearing K 16x21x10 FV	1	1	1
90	3439	2nd gear on layshaft "M1" T=23	1	-	-
91	3757	Needle bearing K 20x24x12	1	1	1
92	3461	Lock ring	1	1	1
93	499	Ball bearing 6005 2RS Din 625	1	1	1
94	1852	Lock ring 47x1.75 Din 472	1	1	1
95	3462	Bearing bush	1	1	1
96	3463	Ball bearing 6005 2RS Din 625	1	1	1
97	1854	Lock ring 55x2 Din 472	1	1	1
98	3464	Lock ring 55x2 Din 625	1	1	1
99	3465	Sprocket T=13	1	1	1
100	1848	Lock ring A 29x1.5 K	1	1	1
101	3466	Needle gauge K 17x21x13	3	3	3
102	749	Bush	1	1	1
103	3440	2nd gear on mainshaft "M" T=21	1	-	-
104	3441	1st gear on mainshaft "M" T=19	1	-	-
105	513	Needle bearing H K 1612	1	1	1
106	514	Needle bearing B K 1616	1	1	1
107	3442	Twin block gear on mainshaft "M" T=21/19	1	-	-
108	3467	Washer 1st gear layshaft	1	1	1
109	555	Gear change lever	1	1	1
110	556	Rubber pad	1	1	1

111	1570	Hexagon screw M 6x25 Din 933	1	1	1
112	1712	Spring B 6 Din 137	1	1	1
113	2503	Gear change crank	1	1	1
114	3399	Pull rod	1	1	1
115	3402	Shifting segment	1	1	1
116	511	Plug	1	1	1
117	3407	Shifting plate	1	1	1
118	3408	Gear rack	1	1	1
119	1824	Tension pin	2	2	2
120	572	O-ring	1	1	1
121	587	Lock ring	1	1	1
122	3410	Hooked ratchet	1	1	1
123	573	Return spring	1	1	1
124	576	Hooked ratchet spring	1	1	1
125	3411	Guide rail	2	2	2
126	3412	Flat head screw M 6x16 Din 923	2	2	2
127	3493	Flat head screw M 6x16 Din 923	2	2	2
128	1712	Spring washer B 6 Din 137	4	4	4
129	1667	Hexagon nut M 6 Din 934	4	4	4
130	3413	Gear selection fork spindle	1	1	1
131	3414	Gear selection fork	3	3	3
132	3415	Pawl pin	1	1	1
133	3422	Compression spring	1	1	1
134	410	Sealing ring A 14x18 Din 7603	1	1	1
135	3416	Locking screw	1	1	1
136	3417	Tension spring holding screw	1	1	1
137	1667	Nut M 6 Din 934	1	1	1
138	652	Kickstarter lever (upper)	1	1	1
139	2508	Kickstarter lever (lower)	1	1	1
140	1874	Ball	1	1	1
141	655	Tension spring	1	1	1
142	656	Rubber pad	1	1	1
143	1840	Lock washer 9 Din 6799	1	1	1
144	1816	Tension pin 3x10 Din 1481	1	1	1
145	3471	Kickstarter shaft	1	1	1
146	659	O-ring	2	2	2
147	1570	Hexagon screw M 6x25 Din 933	1	1	1
148	1704	Spring ring B 6 Din 127	1	1	1
149	666	Kickstarter return spring	1	1	1
150	588	Magneto housing complete	1	1	1
151	592	Rotor bolt	1	1	1
152	1714	Spring washer B 8 Din 137	1	1	1
153	1527	Cylinder head screw	1	1	1
154	1730	Washer 4.3 Din 125	1	1	1
155	1702	Spring ring B 4 Din 127	1	1	1
156	611	Magnet rotor	1	1	1
157	1534	Cylinder head screw AM 6x20 Din 84	3	3	3
158	1732	Spring ring B 6 Din 127	3	3	3
159	1704	Washer 6.4 Din 125	3	3	3
160	603	Spark plug	2	2	2
161	609	Contact breaker	1	1	1
162	613	Carburetor complete	1	-	-
163	681	Spacer tube	1	1	1
164	3143	Rubber flange	1	1	1
165	683	Clamp	3	3	3
166	343	Rubber sleeve	1	1	1
167	3681	Crankcase right hand	-	-	1
168	3682	Crankcase left hand	-	-	1
169	709	Crankshaft complete	-	1	1
170	714	Triplex sprocket	-	1	1

171	735	Triplex primary chain 3/8x7/32	-	1	1
172	2577	Clutch housing (triplex T=39)	-	1	1
173	3443	3rd gear on mainshaft "M" T=23	-	1	1
174	3444	Sleeve pinion "G" T=29	-	1	1
175	3445	Layshaft "G" T=16	-	1	1
176	3446	1st gear on layshaft "G1" T=28	-	1	1
177	3447	2nd gear on layshaft "G1" T=24	-	1	1
178	3448	2nd gear on mainshaft "G" T=20	-	1	1
179	3449	1st gear on mainshaft "G" T=17	-	1	1
180	3450	Twin block gear on layshaft "G" T=21/18	-	1	1
181	533	Piston 76.95	-	1	-
182	534	L piston ring	-	1	-
183	2101	R piston ring	-	1	-
184	537	Piston pin	-	1	1
185	715	Cylinder complete with exhaust manifold	-	1	-
186	719	Cylinder head	-	1	-
187	720	Cylinder head gasket	-	1	-
188	2968	Cylinder head stud	-	5	5
189	2110	Piston 81.94	-	-	1
190	2111	L piston ring	-	-	1
191	2591	Cylinder complete with exhaust manifold	-	-	1
192	2593	Cylinder head	-	-	1
193	2582	Cylinder head gasket	-	-	1
194	577	Cover plate	1	1	1
195	579	Locking plate	1	1	1
196	1564	Hexagon screw M 6x10 Din 933	1	1	1
197	614	Carburetor complete	-	1	1
198	467	Exhaust flange	1	1	1
199	298	Exhaust flange gasket	1	1	1
200	1635	Socket screw M 6x25 Din 912	1	1	1
201	1704	Spring ring B 6 Din 127	1	1	1
202	517	Decompression valve cpl	-	1	1
203	410	Sealing ring A 14x18 Din 7603	-	1	1

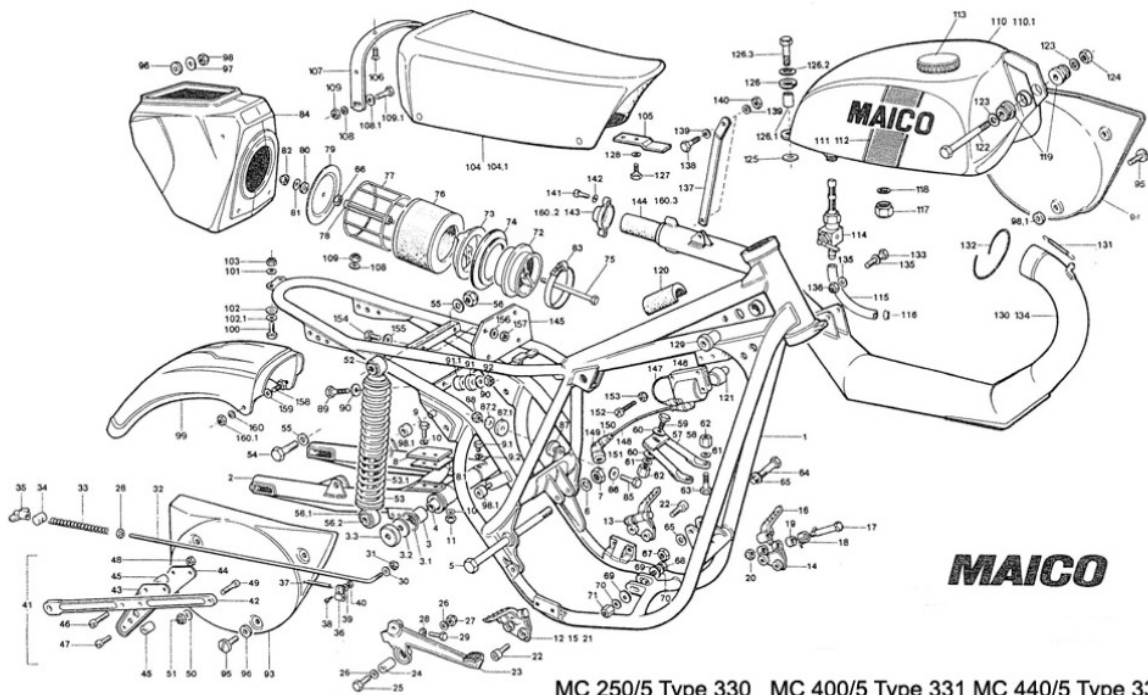

MAICO

MC 250/5 Type 330 MC 400/5 Type 331 MC 440/5 Type 332

Picture No.	Part No.	Description	Quantity		
			250	400	440
1	5	Frame cpl	1	1	1
2	3917	Swing arm cpl	1	1	1
3	3932	Needle cage 2030	2	2	2
3.1	80	O ring	2	2	2
3.2	5008	Washer	2	2	2
3.3	3934	Cover plate for swing arm	2	2	2
4	3933	Spacer bush for swing arm	2	2	2
5	3937	Swing arm spindle	1	1	1
6	1718	Washer	1	1	1
7	5011	Nut for swing arm spindle M 24 x 2.5 Din 980	1	1	1
8	3936	Swing arm plastic pad	1	1	1
8.1	3927	Cover plate	1	1	1
9	1567	Hexagon screw M 6x16 Din 933	2	2	2
9.1	1554	Hexagon screw M 6x6 Din 933	1	1	1
9.2	407	Sealing ring A x 10 Din 7603	1	1	1
10	1732	Washer B 6.4 Din 125	4	4	4
11	1690	Hexagon nut NM 6 Din 980	2	2	2
12	3779	Foot rest right hand cpl	1	1	1
13	3780	Foot rest left hand cpl	1	1	1
14	3564	Foot rest base plate left hand	1	1	1

15	3567	Foot rest base plate right hand	1	1	1
16	3563	Foot rest	2	2	2
17	3569	Bolt M 8x58x70	2	2	2
18	3568	Foot rest return spring left hand	1	1	1
19	3565	Spacer Bush	2	2	2
20	1692	Self locking nut NM 8 Din 980	2	2	2
21	3566	Foot rest return spring right hand	1	1	1
22	1655	Socket screw M 10x25 Din 6912	4	4	4
23	5090	Brake pedal	1	1	1
24	5093	Bushing for brake pedal	1	1	1
25	1500	Hexagon screw M 6x40 Din 931	1	1	1
26	1732	Washer B 6.4 Din 125	2	2	2
27	1690	Lock nut NM 6 Din 980	1	1	1
28	1667	Hexagon nut M 6 din 934	2	2	2
29	1570	Hexagon screw M 6x25 Din 933	1	1	1
30	1732	Washer B 6.4 Din 125	1	1	1
31	1690	Lock nut NM 6 Din 980	1	1	1
32	5089	Rear brake rod	1	1	1
33	242	Spring	1	1	1
34	244	Nipple	1	1	1
35	243	Wing nut	1	1	1
36	237	Clamp	1	1	1
37	236	Spring	1	1	1
38	1527	Cylinder head screw M 4x10 Din 84	1	1	1
39	1702	Spring washer B 6 Din 127	1	1	1
40	1665	Hexagon nut M 6 Din 934	1	1	1
41	3505	Chain guide cpl	1	1	1
42	3506	Rear brake stopper arm	1	1	1
43	3092	Chain guide plate right hand	1	1	1
44	3093	Chain guide plate left hand	1	1	1
45	3094	Sliding rollers	3	3	3
46	1539	Head screw M 6x40 Din 84	2	2	2
47	1550	Head screw M 6x30 Din 84	1	1	1
48	1690	Hexagon nut NM 6 Din 980	3	3	3
49	1652	Socket screw M 8x20 Din 6912	1	1	1
50	1734	Washer B 8.4 Din 125	1	1	1
51	1692	Hexagon nut NM 8 Din 980	1	1	1
52	3944	Shocks cpl (Girling gas shocks)	2	2	2
53	3945	Spring 7.5 (black)	2	2	2
53.1	5075	Spring 7.75 (red)	2	2	2
54	1594	Hexagn screw M 8x40 Din 931	4	4	4
55	1734	Washer B 8.4 Din 125	8	8	8
56	1692	Hexagon nut NM 8 Din 980	4	4	4
56.1	5201	Rubber bush 6454 1661	4	4	4
56.2	5202	Bush 7052 0708	4	4	4
57	3697	Support for cylinder	1	-	-
58	3781	Support for cylinder	-	1	1
59	1589	Hexagon screw M 8x20 Din 933	1	1	1

60	1749	Washer A 8.4 Din 9021	2	2	2
61	1714	Spring washer B 8 Din 137	3	3	3
62	78	Hexagon nut N 8 Din 6330	3	3	3
63	1592	Hexagon screw M 8x30 Din 933	2	2	2
64	1626	Hexagon screw M 10x1.25x60 Din 960	2	2	2
65	1715	Spring washer B 10 Din 137	4	4	4
66	1667	Hexagon nut M 6 Din 934	1	1	1
67	5031	Lock nut VM 10x1.25 Din 980	2	2	2
68	1599	Hexagon screw M 8x60 Din 931	1	1	1
69	1749	Washer B 8.4 Din 9021	2	2	2
70	1714	Spring washer B 8 Din 137	2	2	2
71	78	Hexagon nut M 8 Din 6330	1	1	1
72	3182	Flange for outside air box	1	1	1
73	3183	Air box ring	1	1	1
74	2485	Rubber ring for filter box	1	1	1
75	3758	Hexagon bolt M 6x130x35	1	1	1
76	3181	Foam filter	1	1	1
77	3164	Air filter body	1	1	1
78	3184	Spacer tube	1	1	1
79	3805	Cover for air filter	1	1	1
80	2708	Rubber washer	1	1	1
81	1750	Washer 6.4 Din 9021	1	1	1
82	1690	Hexagon nut NM 6 Din 980	1	1	1
83	348	Clamp	1	1	1
84	3958	Air box	1	1	1
85	1570	Hexagon screw M 6x25 Din 933	2	2	2
86	1732	Washer B 6.4 Din 125	2	2	2
87	3529	Washer	2	2	2
87.1	2708	Rubber washer	2	2	2
87.2	1750	Washer 6.4 Din 9021	2	2	2
88	1690	Hexagon nut NM 6 Din 980	2	2	2
89	1572	Hexagon screw M 6x35 Din 931	2	2	2
90	1750	Washer 6.4 Din 9021	4	4	4
91	2708	Rubber washer	2	2	2
91.1	5029	Spacer washer	2	2	2
92	1690	Nut NM 6 Din 980	2	2	2
93	5205	Side panel right hand	1	1	1
94	5206	Side panel left hand	1	1	1
95	3711	Plastic screw M 6x22	6	6	6
96	2708	Rubber washer	8	8	8
97	1750	Washer 6.4 Din 921	2	2	2
98	1690	Hexagon nut NM 6x18 Din 933	2	2	2
98.1	5029	Spacer washer	2	2	2
99	33	Rear fender (red)	1	1	1
100	1568	Hexagon screw M 6x18 Din 933	2	2	2
101	1732	Washer B 6.4 Din 125	2	2	2
102	2708	Rubber washer	2	2	2
102.1	1750	Washer 6.4 Din 125	2	2	2
103	1690	Hexagon nut NM 6 Din 980	2	2	2
104	5192	Seat cpl (low)	1	1	1
104.1	5200	Seat cpl (high)	(1)	(1)	(1)

105	286	Clamp holder for seat	1	1	1
106	1812	Counter sunk screw M 6x16 Din 964	4	4	4
107	5197	Seat bracket	1	1	1
108	1734	Washer B 8.4 Din 125	2	2	2
108.1	1947	Washer 8,4 Din 9021	2	2	2
109	1692	Hexagon nut NM 8 Din 980	2	2	2
109.1	1588	Hexagon screw M 8x18 Din 933	2	2	2
110	5340	Fuel tank aluminium MC	1	1	1
110.1	5341	Fuel tank aluminium GS	(1)	(1)	(1)
111	3520	Maico emblem left hand	1	1	1
112	3521	Maico emblem right hand	1	1	1
113	3429	Fuel tank cap	1	1	1
114	2831	Gasoline tap	1	1	1
115	3523	Gasoline hose	1	1	1
116	2832	Hose clip	2	2	2
117	5342	Screw cap for fuel tank	1	1	1
118	5243	Sealing ring	1	1	1
119	5344	Tank mounting rubber	2	2	2
120	3527	Rubber pad for tank	2	2	2
121	3866	Moulded rubber mount	2	2	2
122	1604	Hexagon screw M 8x90 Din 931	1	1	1
123	1734	Washer B 8,4 Din 9021	2	2	2
124	1692	Hexagon nut NM 8 Din 980	1	1	1
125	5345	Rubber washer	1	1	1
126	5346	Rubber pressure ring	1	1	1
126.1	5347	Tension bush	1	1	1
126.2	1749	Washer 8,4 Din 9021	1	1	1
126.3	1591	Hexagon screw M 8x25 Din 933	1	1	1
127	1567	Hexagon screw M 6x16 Din 933	2	2	2
128	1704	Lock washer B 6 Din 127	2	2	2
129	5348	Spacer bush for tank	2	2	2
130	3517	Exhaust system cpl	-	1	1
131	5160	Tension Spring	1	1	1
132	896	Asbestos cord	1	1	1
133	1595	Hexagon screw M 8x45 Din 931	1	1	1
134	5216	Exhaust system cpl	1	-	-
135	1735	Washer A 8.4 Din 125	2	2	2
136	1692	Hexagon nut NM 8 Din 980	1	1	1
137	5308	Exhaust brace	1	1	1
138	1567	Hexagon screw M 6x16 Din 933	2	2	2
139	1732	Washer B 6.4 Din 125	4	4	4
140	1690	Hexagon nut NM 6 Din 980	2	2	2
141	1571	Hexagon screw M 6x30 Din 931	2	2	2
142	1704	Spring washer B 6 Din 127	2	2	2
143	3516	End cap	-	1	1
144	3557	Sound proofing material	-	1	1
145	5203	Splash guard	1	1	1
146	1124	Ignition coil	1	1	1
147	605	Ground cable	1	1	1
148	589	High tension lead	1	1	1
149	599	Cable plug	1	1	1
150	600	Rubber sleeve	1	1	1
151	601	Rubber sleeve	2	2	2

152	1530	Head screw M 5x25 Din 84	1	1	1
153	1689	Hexagon nut NM 5 Din 980	2	2	2
154	1567	Hexagon screw M 6x16 Din 933	2	2	2
155	1750	Washer B 6,4 Din 9021	2	2	2
156	1732	Washer B 6,4 Din 125	2	2	2
157	1690	Hexagon nut NM 6 Din 980	2	2	2
158	1567	Hexagon screw M 6x16 Din 933	2	2	2
159	1750	Washer 6,4 Din 9021	2	2	2
160	1732	Washer B 6,4 Din 125	2	2	2
160.1	1690	Hexagon Nut NM 6 Din 980	2	2	2
160.2	5156	End cap	1	-	-
160.3	5155	Sound proofing material	1	-	-



MC 250/5 Type 330 MC 400/5 Type 331 MC 440/5 Type 332

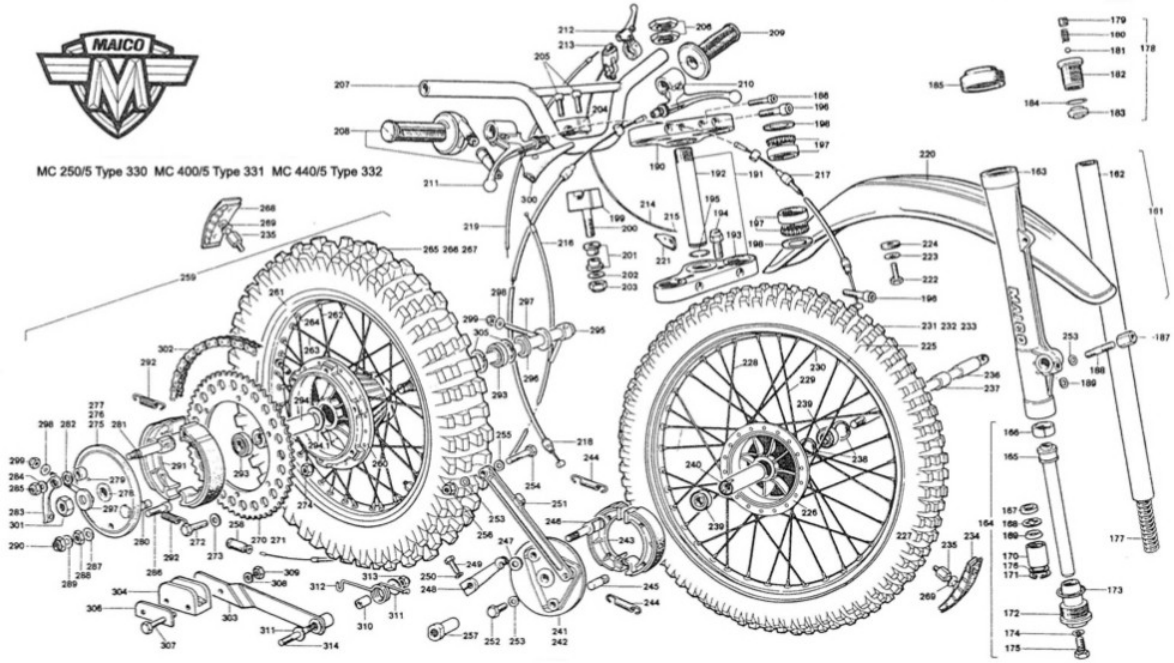

Picture No.	Part No.	Description	Quantity		
			250	400	440
161	5188	Telescopic fork cpl	1	1	1
162	3790	Fork main tube	2	2	2
163	3906	Fork slider tube	2	2	2
164	5353	Damper cpl	2	2	2
165	5351	Damper tube (235)	2	2	2
166	3789	Damper piston ring	2	2	2
167	3913	Damper ring for damper	2	2	2
168	3369	Valve seat	2	2	2
169	3368	Valve	2	2	2
170	3367	Damper insert	2	2	2
171	3366	Locking ring 34 c 1.5 Din 472	2	2	2
172	5354	Damper cone	2	2	2
173	80	O ring 29 x 2.5	2	2	2
174	430	Sealing ring A 8x14 Din 7603	2	2	2
175	1591	Hexagon screw M 8x10 Din 933	2	2	2
176	3777	Spacer washer 0.3 mm (3778/0.5mm)	2	2	2
177	3916	Fork spring 4.6 soft (marked white)	2	2	2
178	3376	Breather screw cpl	2	2	2
179	1785	Stud	2	2	2
180	75	Valve spring	2	2	2
181	1873	Ball 6	2	2	2
182	3377	Breather screw	2	2	2
183	3378	Breather screw plug	2	2	2
184	80	O ring 29 x 2.5	2	2	2
185	3907	Wiper	2	2	2

186	1650	Socket screw M 8x60 Din 912	2	2	2
187	78	Hexagon nut M 8 Din 6330	2	2	2
188	1772	Stud M 8x25 Din 835	2	2	2
189	1734	Washer B 8.4 Din 125	2	2	2
190	3381	Upper cross head	1	1	1
191	3371	Lower cross head cpl (with steering tube)	1	1	1
192	3373	Steering tube	1	1	1
193	3372	Lower cross head	1	1	1
194	226	Locking bolt	2	2	2
195	3375	Spring ring A 26 Din 7993	1	1	1
196	1657	Socket screw M 10x40 Din 912	4	4	4
197	3297	Roller bearing L 44649-610	2	2	2
198	3296	Nilos ring	2	2	2
199	90	Handlebar clamp lower	2	2	2
200	1661	Socket screw M 10x60 Din 6912	2	2	2
201	15	Rubber buffer	4	4	4
202	1758	Washer	2	2	2
203	1693	Hexagon nut M 8x30 Din 912	2	2	2
204	88	Handlebar clamp upper	2	2	2
205	1646	Socket screw M 8x30 Din 912	4	4	4
206	3533	Hexagon nut	2	2	2
207	3784	Handlebar, high	1	1	1
208	2511	Twist grip cpl (with adjusting screw and rubber sleeve)	1	1	1
209	2512	Rubber grip	1	1	1
210	145	Clutch lever cpl	1	1	1
211	146	Brake lever cpl	1	1	1
212	148	Decompression lever cpl	-	1	1
213	571	Kill button	1	1	1
214	2608	Isolation hose	1	1	1
215	2618	Cable	1	1	1
216	2456	Throttle cable	1	1	1
217	486	Brake cable	1	1	1
218	311	Clutch cable	1	1	1
219	305	Cable for decompressor	-	1	1
220	34	Front fender (red)	1	1	1
221	598	Cable plug waterproof			
222	1569	Hexagon screw M 6x20 Din 933	4	4	4
223	1750	Washer A 6.4 Din 9021	4	4	4
224	2708	Rubber washer	4	4	4
225	3964	Front wheel cpl (with tire)	1	1	1
226	3959	Front drum (magnesium)	1	1	1
227	3497	Alum. Front rim 1.60x21"	1	1	1
228	2432	Spoke for front wheel right side (200mm)	18	18	18
229	2433	Spoke for front wheel left side (243 mm)	18	18	18
230	210	Spoke nipple M 4	36	36	36
231	2003	Tire 3.00x21"	1	1	1
232	2002	Air tube 3.00x21"	1	1	1
233	2001	Rim strap	1	1	1
234	168	Tire holder front cpl	1	1	1
235	289	Nut for tire holder	2	2	2
236	169	Front axle	1	1	1
237	2429	Spacer bush	1	1	1

238	1853	Lock ring 35x1.5 Din 472	2	2	2
239	2427	Ball bearing 6202 RS din 625	2	2	2
240	2428	Spacer tube	1	1	1
241	2416	Front brake plate cpl (with brake shoes and brake lever)	1	1	1
242	2417	Front brake plate only	1	1	1
243	1322	Brake shoe	2	2	2
244	1323	Tension spring	2	2	2
245	2418	Pivot bolt	1	1	1
246	2419	Brake toggle	1	1	1
247	187	Rubber washer	1	1	1
248	1324	Front brake lever	1	1	1
249	1569	Hexagon screw M 6x20 Din 933	1	1	1
250	1704	Lock washer B 6 Din 1277	1	1	1
251	2424	Front brake rod	1	1	1
252	1589	Hexagon screw M 8x20 Din 933	1	1	1
253	1714	Lock washer B 8 Din 1377	4	4	4
254	1594	Hexagon screw M 8x40 Din 931	1	1	1
255	1734	Washer B 8.4 Din 125	1	1	1
256	1692	Hexagon nut NM 8 Din 980	1	1	1
257	2430	Threaded bush	1	1	1
258	651	Rubber sheet	1	1	1
259	3883	Rear wheel cpl (with tire, brake plate, axle and sprocket)	1	1	1
260	3868	Rear brake drum (magnesium)	1	1	1
261	3228	Rear rim aluminium 2.15x18"	1	1	1
262	3198	Spokes for rear wheel right side (139 mm)	18	18	18
263	3199	Spokes for rear wheel left side (196 mm)	18	18	18
264	210	Spoke nipple	36	36	36
265	2008	Tire 4.50x18"	1	1	1
266	2015	Air tube 4.50x18"	1	1	1
267	2005	Rim strap	1	1	1
268	2434	Tire holder rear cpl with nut	1	1	1
269	1734	Washer B 8.4 Din 125	2	2	2
270	3227	Sprocket 56T	1	1	1
271	288	Sprocket 52T	(1)	(1)	(1)
272	3280	Hexagon screw M 7x40 Din 933	6	6	6
273	1713	Spring washer B 7 Din 137	6	6	6
274	1691	Hexagon nut NM 7 Din 980	6	6	6
275	3186	Rear brake plate cpl (with brake shoes and brake lever)	1	1	1
276	3187	Rear brake plate	1	1	1
277	3188	Cover plate	1	1	1
278	183	Spacer bush	2	2	2
279	1901	Oval head nail 3x8 Din 1476	1	1	1
280	3189	Pivot bolt	1	1	1
281	151	Brake toggle	1	1	1
282	187	Rubber washer	1	1	1
283	3190	Brake lever	1	1	1
284	1734	Washer B 8.4 Din 125	1	1	1

285	1692	Hexagon nut NM 8 Din 980	1	1	1
286	3270	Socket screw M 10x40 Din 6912	1	1	1
287	1715	Washer B 10.5 Din 137	1	1	1
288	1674	Hexagon nut M 10 Din 934	1	1	1
289	1735	Washer B 10.5 Din 125	1	1	1
290	1693	Hexagon nut NM 10 Din 980	1	1	1
291	188	Brake shoe	2	2	2
292	1323	Tension spring	2	2	2
293	205	Ball bearing 6303 2 RS C3	2	2	2
294	3873	Spacer tube (109 mm for magn. Drum)	1	1	1
294.1	3874	Washer	2	2	2
295	3277	Rear axle	1	1	1
296	3880	Spacer ring (19.5 mm)	1	1	1
297	223	Chain tensioner	2	2	2
298	1734	Washer B 8.4 Din 125	2	2	2
299	1692	Hexagon nut NM 8 Din 980	2	2	2
300	3142	Cover for hand levers (magura)	2	2	2
301	1683	Hexagon nut M 16x1.5 Din 934	1	1	1
302	3708	Chain with master link 5/8x1/4" 118 links	1	1	1
303	5010	Chain tensioner arm	1	1	1
304	5015	Chain tensioner pad	1	1	1
305	1852	Spring ring 47x1.75 Din 472	2	2	2
306	5017	Plate for chain tensioner	1	1	1
307	1580	Hexagon screw M 6x45 Din 933	2	2	2
308	1732	Washer B 6.4 Din 125	2	2	2
309	1690	Lock nut NM 6 Din 980	2	2	2
310	5019	Spacer bush for chain tensioner	1	1	1
311	1749	Washer A 8.4 Din 9021	2	2	2
312	5020	Spring for chain tensioner	1	1	1
313	1692	Hexagon nut NM 8 Din 980	1	1	1
314	1774	Stud M 8 Din 835	1	1	1